



Fastener
Solutions

11" Releasable Cable Ties Marketing Specifications

For the following part numbers:

10367-0
10368-0
10369-0
10370-0

August 1, 2018

EVERY DENNISON MARKETING SPECIFICATION

TOLERANCES: IN. = ± .030 In
MM = ± 0.7 mm

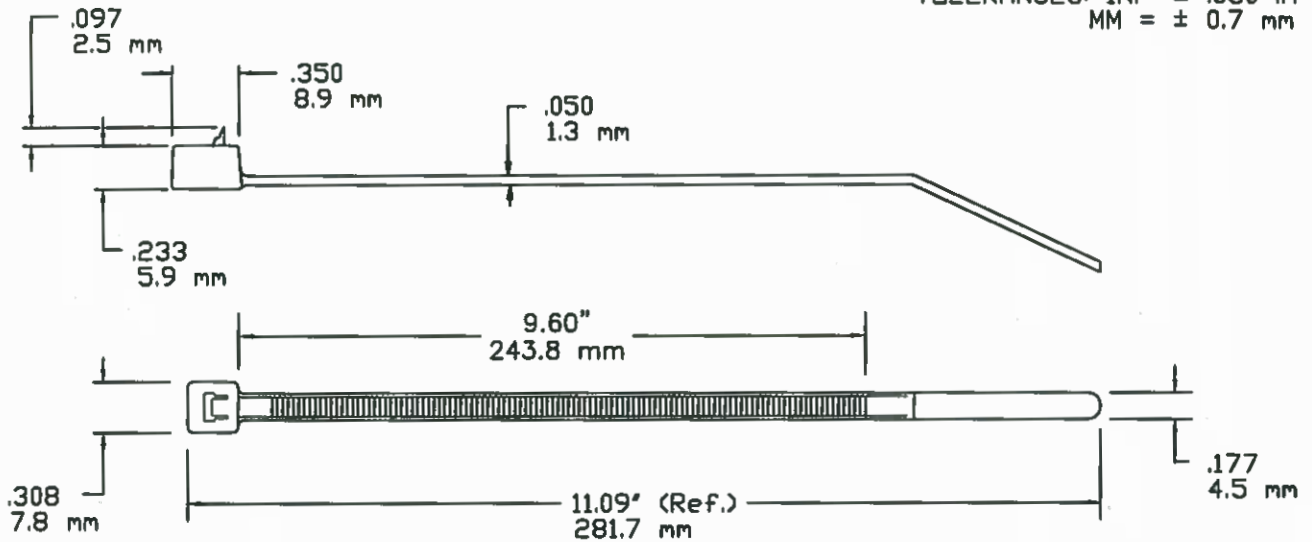

NOT TO SCALE

LOOP TENSILE STRENGTH:	50 LBF / 220N MIN. PER AS-23190
OPERATING TEMPERATURE:	-40°F (-40°C) TO 185°F (85°C)
MIN. INSTALLATION TEMP:	32°F (0°C)
MATERIAL:	NYLON 6/6
WEIGHT:	.06878 oz. / 2.02 grams
BUNDLE DIAMETER:	∅0.063"/1.59mm TO ∅3.0"/76.2mm
PACKAGED IN:	1000/BAG, 5000/CASE

NOTE: THESE CABLE TIES ARE PLENUM RATED AND HAVE A FLAMMABILITY RATING OF V2.



FASTENER DIVISION
FITCHBURG, MA 01420 U.S.A.
TEL. 1-800-225-5913
MA. 978-353-8157



E57800
TYPE11

DESCRIPTION:

11" / 280mm CABLE TIE, RELEASABLE
NATURAL

APPROVAL:

J. Boyle 9-18-2015

STOCK NO.

10367-0

REV

F

AVERY DENNISON MARKETING SPECIFICATION

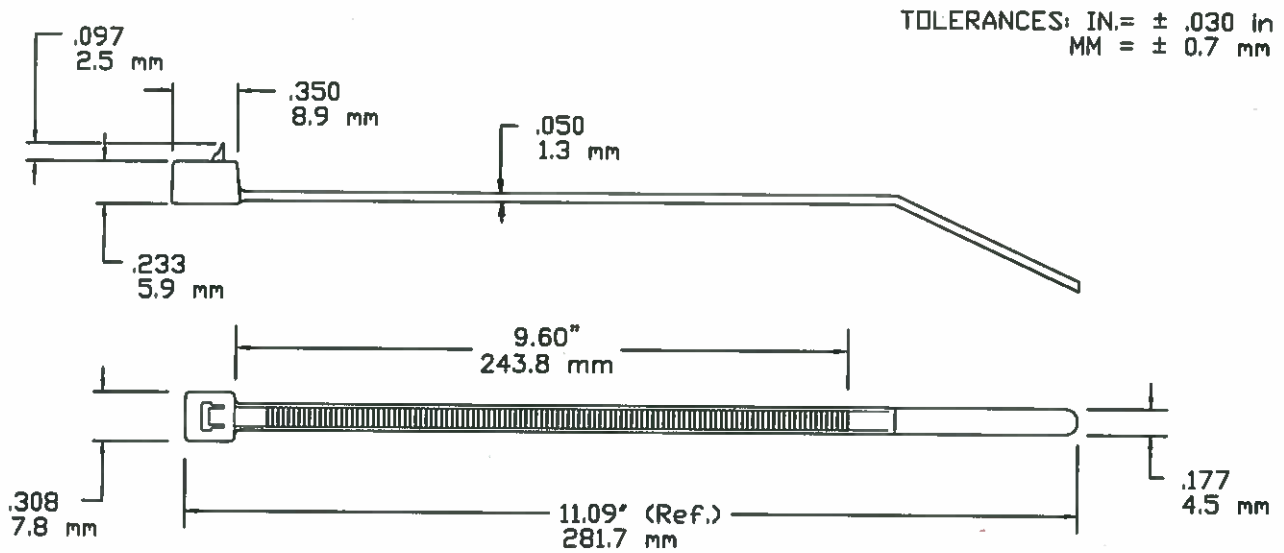

NOT TO SCALE

LOOP TENSILE STRENGTH:	50 LBF / 220N MIN. PER AS-23190
OPERATING TEMPERATURE:	-40°F (-40°C) TO 221°F (105°C)
MIN. INSTALLATION TEMP:	32°F (0°C)
MATERIAL:	NYLON 6/6
WEIGHT:	.06878 oz. / 2.02 grams
BUNDLE DIAMETER:	Ø0.063"/1.59mm TO Ø3.0"/76.2mm
PACKAGED IN:	1000/BAG, 5000/CASE

NOTE: THESE CABLE TIES ARE PLENUM RATED AND HAVE A FLAMMABILITY RATING OF V2.



FASTENER DIVISION
FITCHBURG, MA 01420 U.S.A.
TEL. 1-800-225-5913
MA. 978-353-8157



E57800
TYPE 11

DESCRIPTION:

11" / 280mm CABLE TIE, RELEASABLE
BLACK HEAT STABILIZED

APPROVAL:

L. Boyle 9-18-2015

STOCK NO.

10368-0

REV

F

EVERY DENNISON MARKETING SPECIFICATION

TOLERANCES: IN. = ± .030 in
MM = ± 0.7 mm

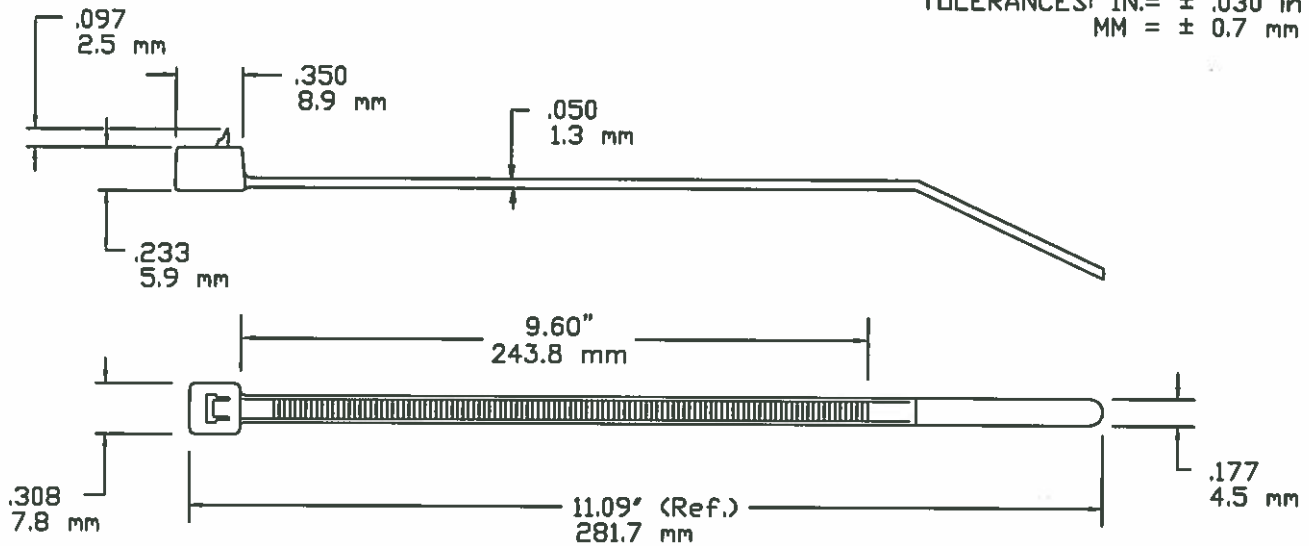

NOT TO SCALE

LOOP TENSILE STRENGTH:	50 LBF / 220N MIN. PER AS-23190
OPERATING TEMPERATURE:	-40°F (-40°C) TO 176°F (80°C)
MIN. INSTALLATION TEMP:	32°F (0°C)
MATERIAL:	NYLON 6/6
WEIGHT:	.06878 oz. / 2.02 grams
BUNDLE DIAMETER:	∅0.063"/1.59mm TO ∅3.0"/76.2mm
PACKAGED IN:	1000/BAG, 5000/CASE

NOTE: THESE CABLE TIES ARE UV RESISTANT AND HAVE A FLAMMABILITY RATING OF V2.



FASTENER DIVISION
FITCHBURG, MA 01420 U.S.A.
TEL. 1-800-225-5913
MA. 978-353-8157



E57800
TYPE 11

DESCRIPTION:

11" / 280mm CABLE TIE, RELEASABLE
BLACK WEATHER RESISTANT

APPROVAL:

J. Boyle 9-18-2015

STOCK NO.

10369-0

REV

F

EVERY DENNISON MARKETING SPECIFICATION

TOLERANCES: IN. = ± .030 in
MM = ± 0.7 mm

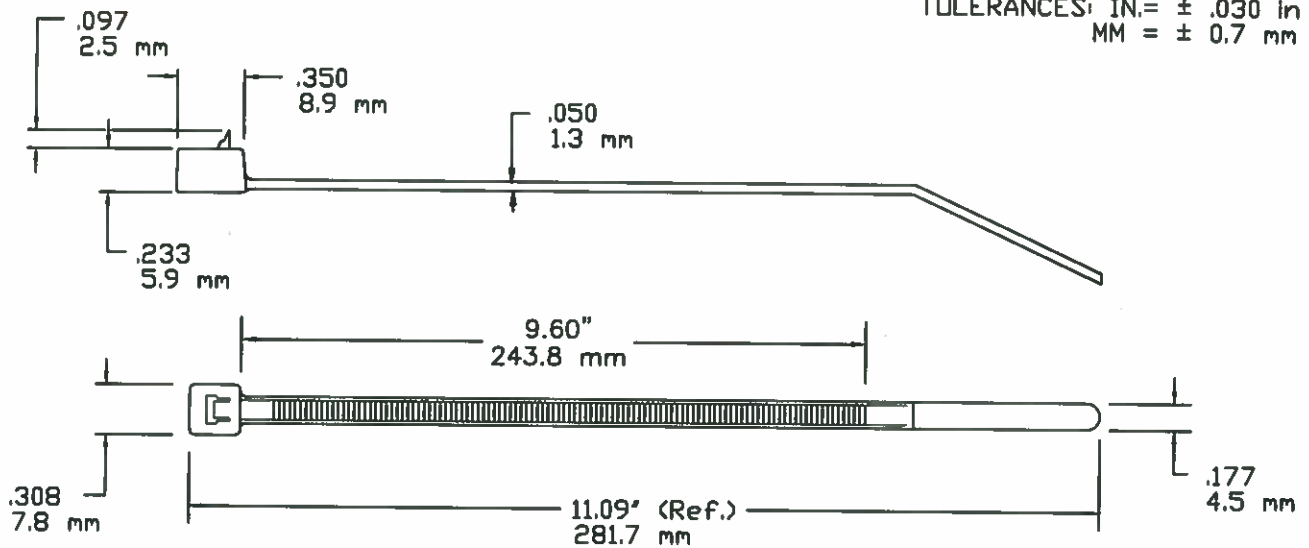

NOT TO SCALE

LOOP TENSILE STRENGTH:	50 LBF / 220N MIN. PER AS-23190
OPERATING TEMPERATURE:	-40°F (-40°C) TO 185°F (85°C)
MIN. INSTALLATION TEMP:	32°F (0°C)
MATERIAL:	NYLON 6/6
WEIGHT:	.06878 oz. / 2.02 grams
BUNDLE DIAMETER:	∅0.063"/1.59mm TO ∅3.0"/76.2mm
PACKAGED IN:	100/BAG, 1000/CASE

NOTE: THESE CABLE TIES ARE PLENUM RATED AND HAVE A FLAMMABILITY RATING OF V2.



FASTENER DIVISION
FITCHBURG, MA 01420 U.S.A.
TEL. 1-800-225-5913
MA. 978-353-8157



E57800
TYPE11

DESCRIPTION:

11" / 280mm CABLE TIE, RELEASABLE
NATURAL

APPROVAL:

J. Boyle 9-18-2015

STOCK NO.

10370-0

REV

B